



**Dafne Marchesini**  
***PORTFOLIO***



## Dafne Marchesini

Con oltre 15 anni di esperienza, sono specializzata nella progettazione nello sviluppo di siti web.

Mi occupo dell'intero ciclo di vita di un sito, dalla creazione del mock-up alla pubblicazione online.

Realizzo banner di tendenza, icone e loghi.

Ho molta dimestichezza con l'editing multimediale: realizzo video e animazioni con particolare attenzione alla coerenza visiva.

## Contatti



26/04/1982



dafne.marchesini@gmail.com



Rimini



dafnemarchesini.it

## Interessi



## Competenze



## Programmi





***LOGHI***



# PIZZA DA GIGI

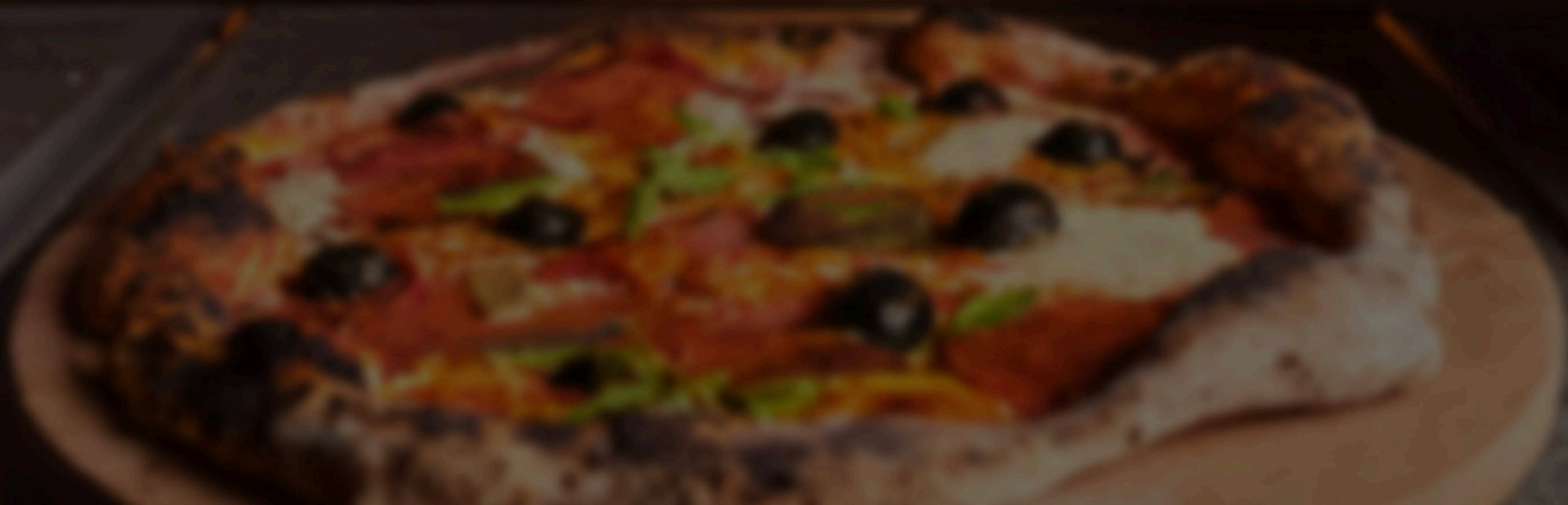



# PIZZA DA GIGI



## Processo di Creazione del Logo - Pizza da Gigi

### Sketch Digitale su Procreate

Ho iniziato disegnando il gatto su **Procreate**, esplorando varie espressioni per renderlo simpatico e appetitoso. L'uso di livelli ha permesso di lavorare con precisione sui dettagli, come la fetta di pizza e il muso del gatto.

### Vettorializzazione in Adobe Illustrator

Il disegno è stato poi vettorializzato su **Illustrator** per assicurare una qualità perfetta su ogni supporto. In questa fase ho perfezionato le linee e scelto colori vivaci, ideali per il brand.

### Ottimizzazione per la Stampa

Infine, il file è stato preparato per la stampa, con una versione nitida e resistente per lo scatolone della pizza, che mantiene vividi i dettagli anche su cartone.









## **Processo di Creazione del Logo - Hero Gym**

### **Ideazione e Bozzetto su Procreate**

Ho iniziato con un **bozzetto** su Procreate, sviluppando un design energetico e moderno che esprimesse forza e determinazione, ideali per il brand Hero Gym. Qui ho lavorato su forme e linee audaci, concentrandomi su un simbolo distintivo e facilmente riconoscibile.

### **Vettorializzazione in Adobe Illustrator**

Il bozzetto è stato poi vettorializzato su Illustrator per garantire un risultato perfettamente scalabile. Le linee e i dettagli sono stati perfezionati per mantenere il logo chiaro e di impatto anche su piccole dimensioni.

### **Applicazione su Prodotti**

Infine, il logo è stato adattato per diversi prodotti della palestra, come **borsoni, t-shirt e borracce**. Ogni applicazione è stata testata per assicurare che i dettagli rimanessero nitidi e i colori vivaci, mantenendo un'estetica coerente e di qualità su ogni materiale.



**HANDYMAN**  
*il Tuttofare*

### **Descrizione del Logo - Handyman: Il Tuttofare**

Il logo di Handyman - Il Tuttofare è stato progettato per evocare affidabilità, professionalità e un tocco di simpatia, richiamando l'energia e lo spirito di un personaggio da videogame.

### **Bozzetto e Stile su Procreate**

Il processo è iniziato su Procreate, dove è stato disegnato un personaggio iconico e amichevole che rappresentasse Handyman, pronto a "salvare la giornata" in ogni situazione. Sono state esplorate diverse espressioni e pose per creare un'immagine che trasmettesse simpatia e competenza. Le linee morbide e il design del personaggio richiamano lo stile di un eroe da videogame, rendendo il logo familiare e riconoscibile.

### **Vettorializzazione in Adobe Illustrator**

Dopo il bozzetto, l'immagine è stata trasferita in Adobe Illustrator per la vettorializzazione. Questo passaggio ha garantito un risultato nitido e scalabile su ogni tipo di supporto, dai biglietti da visita alle insegne. Su Illustrator, il personaggio è stato perfezionato, aggiungendo dettagli come il cappellino da lavoro e strumenti tipici (come un martello o un cacciavite) per identificare subito la sua funzione di "tuttofare".

### **Ottimizzazione e Applicazione su Materiali Promozionali**

Una volta finalizzato, il logo è stato preparato per essere applicato su vari materiali promozionali, come camioncini aziendali, abbigliamento, volantini, biglietti da visita e la bicicletta utilizzata per la professione. La palette di colori è stata calibrata per risultare vivace e facilmente riconoscibile, in modo da catturare l'attenzione e trasmettere affidabilità.

# HANDYMAN

*il Tuttofare*



# HANDYMAN

*il Tuttofare*



**HANDYMAN**

*Fattofare*



A photograph of a self-storage facility aisle. The aisle is paved and runs between two rows of storage units. On the left, there are units with large glass windows. On the right, there are units with solid metal doors, some of which are roll-up doors. The sky is a clear, bright blue. A large, stylized text overlay is centered in the aisle. The text is yellow with a white outline and a drop shadow. The word 'LOCK' has a padlock icon for the letter 'O'. The word 'STOCK' has a key icon for the letter 'T'. Below the main text is the phrase '—SELF STORAGE—' in a smaller, similar font.

# LOCK & STOCK

—SELF STORAGE—

**LOCK &  
STOCK**  
—SELF STORAGE—

**LOCK &  
STOCK**  
—SELF STORAGE—

**LOCK &  
STOCK**  
—SELF STORAGE—

**LOCK &  
STOCK**  
—SELF STORAGE—

**LOCK &  
STOCK**  
—SELF STORAGE—

### **Descrizione del Logo - Lock & Stock**

Il logo di Lock & Stock è stato progettato per **riflettere sicurezza**, affidabilità e praticità, rappresentando al meglio l'idea di un servizio di **noleggio box** dove le persone possono riporre i propri beni in totale tranquillità.

### **Ideazione e Bozzetto su Procreate**

Il progetto è partito con la creazione di un concetto su Procreate, esplorando simboli che evocassero l'idea di protezione e ordine. Sono stati sviluppati diversi sketch, tra cui quelli che univano l'immagine di un lucchetto con un elemento che rappresentasse lo stoccaggio (come una scatola o un deposito). L'obiettivo era creare un logo che fosse facilmente riconoscibile e che trasmettesse un senso di sicurezza e organizzazione.

### **Vettorializzazione in Adobe Illustrator**

Dopo aver scelto il bozzetto finale, il disegno è stato portato in Adobe Illustrator per la vettorializzazione. Questo passaggio ha garantito che il logo fosse perfetto per essere riprodotto su qualsiasi supporto, dal sito web ai cartelloni pubblicitari. Il lucchetto stilizzato è stato affinato con linee nette e moderne, mentre il simbolo del "box" è stato reso semplice e intuitivo per un impatto visivo immediato.

### **Ottimizzazione per la Stampa e Materiale Promozionale**

Una volta completato il design, il logo è stato adattato per l'applicazione su diversi materiali, come insegne, brochure e articoli promozionali. La scelta dei colori ha enfatizzato la serietà e la sicurezza del servizio, utilizzando tonalità di blu e grigio che richiamano tranquillità e affidabilità.











### **Processo di Creazione del Logo - Cube**

#### **Sketch Digitale su Procreate**

Ho iniziato disegnando il bidone dei materiali si scarto dei camper su **Procreate**, esplorando varie espressioni per renderlo chiaro e di facile intuizione. L'uso di livelli ha permesso di lavorare con precisione sui dettagli.

#### **Vettorializzazione in Adobe Illustrator**

Il disegno è stato poi vettorializzato su **Illustrator** per assicurare una qualità perfetta su ogni supporto. In questa fase ho perfezionato le linee e scelto colori legati al prodotto finito.

#### **Ottimizzazione per la Stampa**

Infine, il file è stato preparato per la stampa, con una versione nitida e resistente per la macchina, che mantiene vividi i dettagli anche su metallo.



1

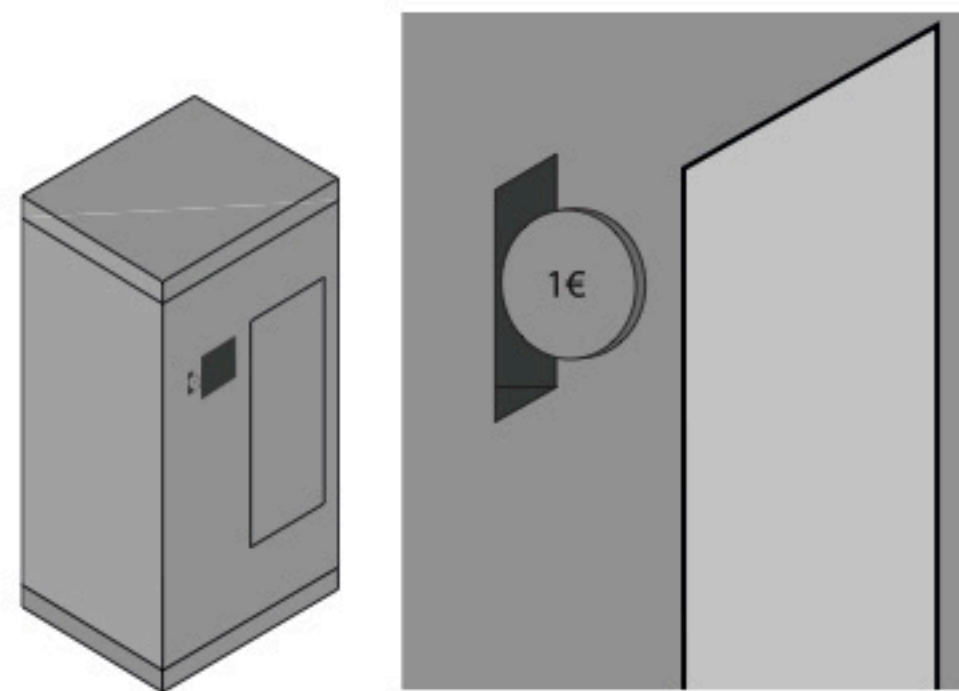

2

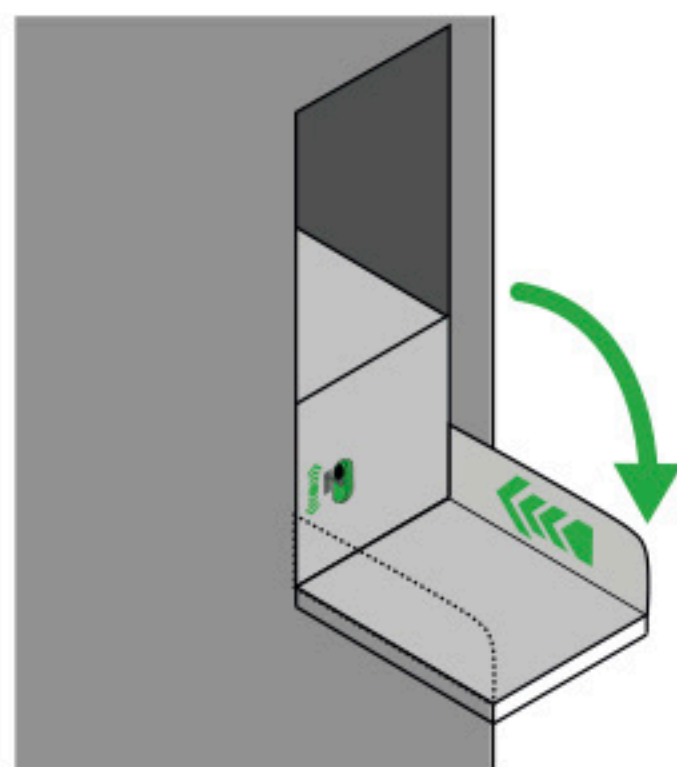

3

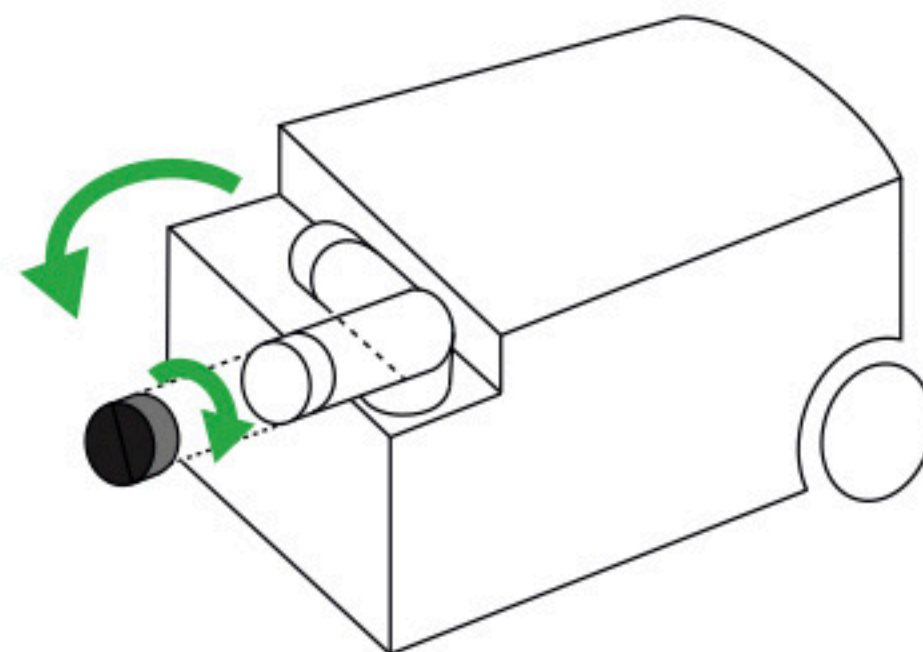

4

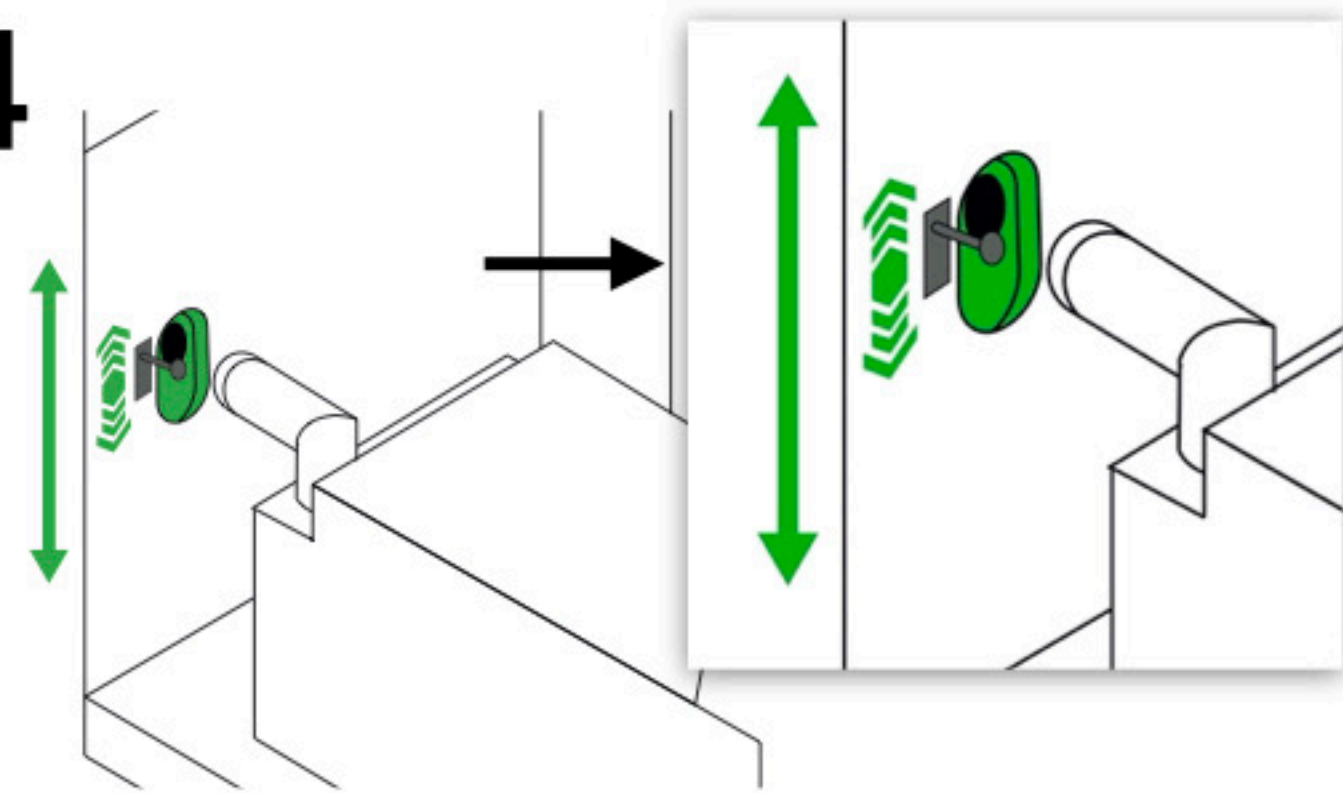

5

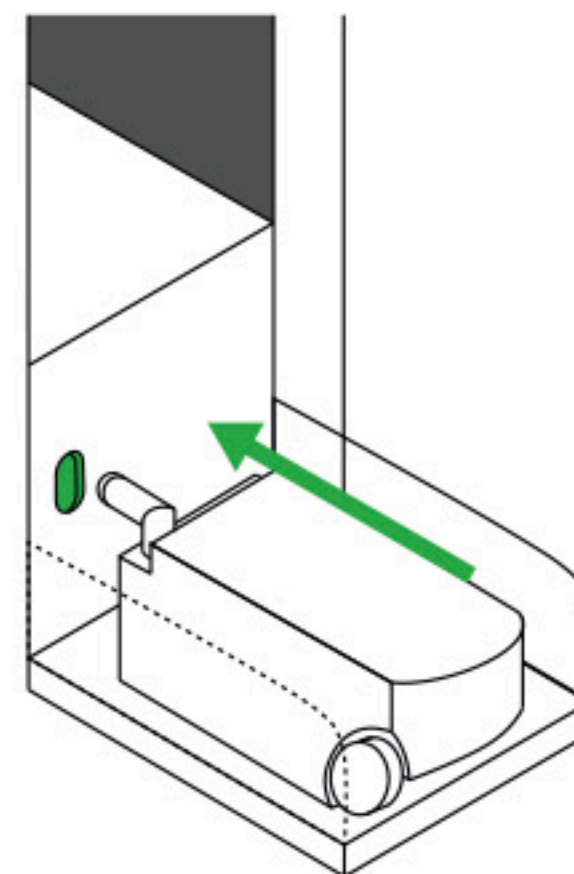

6

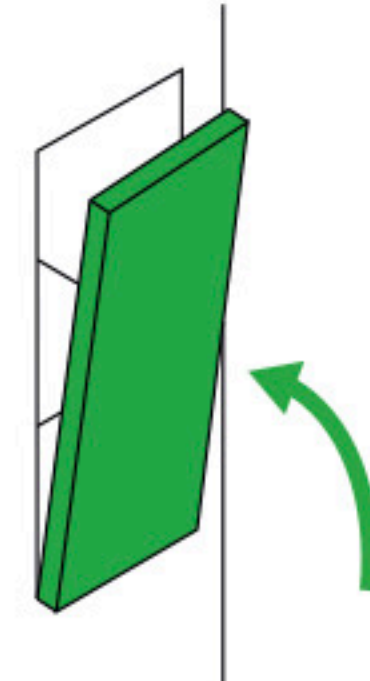



***Web design***

Aperto 365 giorni l'anno  
da **MEZZOGIORNO** a **TARDA NOTTE**



**PRENOTA ORA!**



[HOME](#) [IL BOUNTY](#) [PROGRAMMAZIONE](#) [EVENTI PRIVATI](#) [EVENTI](#) [NEWS](#) [SHOP](#) [PIANO FIDELITY](#) [CONTATTI](#)

# BOUNTY RIMINI LA NAVE DEL DIVERTIMENTO



# ***Bounty Rimini***

## **Benvenuti a bordo!**

Questo è il sito del Bounty di Rimini.

Ho solcato i mari digitali con **WordPress** e scolpito il nostro design con **Elementor**, garantendo un'esperienza interattiva e coinvolgente.

Non solo ho curato la navigazione e l'aspetto (**CSS-JAVA SCRIPT-HTML**), ma anche le icone che vedete sono frutto della mia **creatività su Illustrator**.

Salite a bordo e lasciatevi trasportare dall'atmosfera unica di questo sito.

Buon viaggio!





CONTACTS



VI.BE.MAC. INDUSTRIAL SEWING MACHINES FOR DENIM

# INDUSTRIAL SEWING MACHINE

40 YEARS OF EXPERIENCE IN LEAD

40 YEARS  
EXPERIEN



HIGH QUALITY



FLEXIBLE



HIGH SPEED



EFFICIENCY



FASHION STYLES



OPERATOR FRIENDLY

Important Notice!



# OUR STRENGTHS

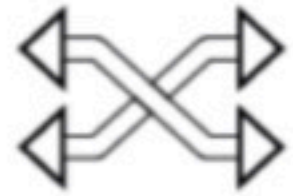

The keyword of Vibemac is automation and the factor that made it successful have always been the concept of flexible automation, able to follow the always faster fashion demand with an unique solution. Jeans and Denim



Our company policy is to aim for product quality. We pay close attention to the materials and their durability over time. Our machines, always with the right maintenance, can be indestructible. They are built to last.



We are present in more than 20 offices around the world. We can follow you step by step, from purchase to technical assistance.



Thanks to our two new lines, B-line and S-line, which integrate the main V-line, we can guarantee a complete solution for your production line. Industrial sewing machine.



Our Research and Development department constantly works in search of more and more innovative solutions. We work closely with our collaborators around the world and we use in-depth market research to best meet the demands of our customers.



Since 1980, when Mr Carlo Guerreschi had the intuition, Vi.Be.Mac. has specialized in sewing jeans trousers. We have over 40 years of experience to sewing denim. Now we make industrial sewing machine for denim.





**WARRANTY SYSTEM**

Registered users – Reserved area



**SPARE PARTS CATALOGUE**

Registered users – Reserved area



**TUTORIAL FOR SPARE PARTS CATALOGUE**

Download PDF guide for on-line shop e warranty system



**LATEST CATALOGUES**

V-Line, S-Line and B-Line latest catalogues



**Reparation Form**

Download and fill out the Repair form document and send it to [customer@vbm-grp.com](mailto:customer@vbm-grp.com). Please wait our approval before shipping.

**DOWNLOAD**



# *Vibemac SpA*

Eccoci nel mondo della perfezione sartoriale!

Vi.Be.Mac. SpA, leader nella produzione di macchine da cucire specializzate nel jeans.

Attraverso l'uso avanzato di WordPress e WpBackery, ho trasformato lo spazio digitale in un punto di riferimento.

Utilizzando HTML, CSS e JavaScript, ho personalizzato ogni aspetto del sito, riflettendo l'artigianato e la precisione dell'azienda.

Ogni dettaglio visivo, è stato plasmato con attenzione per offrirvi un'esperienza di navigazione fluida e coinvolgente.

Benvenuti nel futuro della produzione di jeans!





# NEED A SUPPORT?

ViBeMac contacts - e-mail

## CUSTOMER CARE



Do you already own one of our machines and do you need assistance?

Please send us an e-mail to: [customercare@vbm-grp.com](mailto:customercare@vbm-grp.com)

We will help you as soon as possible!

## SALES



Have questions about buying a Vi.Be.Mac. machine?

Please send us an e-mail to: [sales@vbm-grp.com](mailto:sales@vbm-grp.com)

We will show you the best solution for your business!

## ACCOUNTING



Do you need support about payments and billing?

Please send us an e-mail to: [accounting@vbm-grp.com](mailto:accounting@vbm-grp.com)

We provide you with assistance!



THIS IS CUSTOM HEADING ELEMENT



# TAKE A STEP INTO THE FUTURE TODAY

We are the right solution for your business! Contact us! We will assist you with a specialized support to design your production line for Jeans with our industrial sewing machine.

[CONTACT VIBEMAC NOW](#)

What we can do for you

## SERVICES



### CATALOGUES

Latest V-Line, S-Line E B-Line Catalogues!

[PDF CATALOGUES](#)



### SPARE PARTS CATALOGUE

Registered User, Reserved Area!

[GO TO ON-LINE CATALOGUE](#)



### OTHER SERVICES

Click To Go To Services Page!

[GO TO SERVICE PAGE](#)



# Lab 20

LAB 20 Online è stato progettato con cura per riflettere l'identità del marchio e fornire una navigazione coinvolgente. Ogni elemento, dal layout all'uso del colore, è stato attentamente selezionato per creare un'esperienza visiva accattivante.

## **Integrazione di WordPress e WooCommerce:**

Per garantire la massima flessibilità e funzionalità, ho scelto di implementare il sito utilizzando WordPress come piattaforma principale e WooCommerce per gestire il catalogo prodotti. Questa combinazione offre una gestione del contenuto agevole e un'esperienza di shopping fluida.

**Responsive Design:** Il sito è completamente responsive, adattandosi in modo armonioso a diverse dimensioni di schermi e dispositivi. Questa caratteristica assicura che gli utenti possano accedere al sito in modo ottimale da qualsiasi dispositivo.

## MASK 4 LIFE

#mask4life



### ABOUT LAB20

Lab20 nasce per soddisfare le esigenze di materiale sanitario sorte con l'emergenza Covid-19. Produciamo mascherine chirurgiche di tipo IIR di primissima qualità, morbide, confortevoli con BFE>99%

La nostra azienda è certificata ISO 9001

Tutti i nostri prodotti sono MADE IN ITALY

### PRODUCTS

#### MASCHERINE CHIRURGICHE (50PZ)

### PRODUCTS



#### MASCHERINE CHIRURGICHE (50PZ) MC-VID01

Mascherina chirurgica monouso Tipo IIR a tre strati, certificata, in tessuto non tessuto TNT in polipropilene PP idrorepellente opaco, inodore, con filtro ad alta efficienza, morbida, ipoallergenica, buona permeabilità all'aria, non contiene fibre di vetro, additivi, lattice, non protegge contro gas e/o vapori, non è sterile.

Potere filtrante (BFE) > 99,5%

Normative di riferimento UNI EN ISO 14683 UNI EN ISO 10993

Modello: MC-VID01 - taglia unica adulto

Confezione 50 mascherine monouso.

#### DESCRIZIONE PRODOTTO:

Mascherina chirurgica di Tipo IIR

Le maschere di Tipo IIR soddisfano i più elevati requisiti prestazionali per le maschere resistenti a proiezioni (spruzzi) e possono essere utilizzate in ambiti ospedalieri per la protezione del paziente dai germi infettivi e per la protezione del personale sanitario da contaminazione da fluidi biologici.

**€13,00 + IVA - SCATOLA DA 50 PEZZI**

[GO TO SHOP](#)



#### MASCHERINE SANITARIE

La mascherina sanitaria è costituita da due strati di TNT da 40 gr/m2 in polipropilene idrorepellente.

Confezione 50 mascherine monouso.

#### DESCRIZIONE PRODOTTO:

Mascherina filtrante costituita da due strati di TNT da 40 gr/m2 in 100%





0.15€/PZ + IVA - SCATOLA DA 50 PEZZI

GO TO SHOP

## CONTATTACI



Labventi S.r.l.

Sede Legale:

Corso Porta Nuova, 133

37122 Verona

C.F. e P.IVA 04709710232

Nome \*

Nome Cognome

Email \*

Commento o messaggio \*

Invia



HOME

SHOP

CARRELLO

IL MIO ACCOUNT

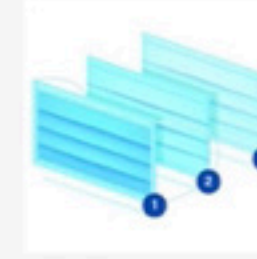

mascherine chirurgiche

**MASCHERINA CHIRURGICA (50PZ)  
MC-VID01, MARCATA CE**

€18,00

Mascherina chirurgica Tipo IIR, monouso non sterile, marcata CE, made in Italy

Modello: MC-VID01 – taglia unica adulto

1

AGGIUNGI AL CARRELLO

### DESCRIPTION

Mascherina chirurgica di Tipo IIR

Le maschere di Tipo IIR soddisfano i più elevati requisiti prestazionali per le maschere resistenti a proiezioni (spruzzi) e possono essere utilizzate in ambiti ospedalieri per la protezione del paziente dai germi infettivi e per la protezione del personale sanitario da contaminazione da fluidi biologici.

### DETTAGLI TECNICI:

#### MATERIALE (3 STRATI):

1. Superficie esterna: Polipropilene Spunbond 25 g/m<sup>2</sup>
2. Filtro: Polipropilene melt-blown 25 g/m<sup>2</sup>
3. Superficie interna: Polipropilene Spunbond 25 g/m<sup>2</sup>

Barretta stringinaso conformabile.

Elastici in poliester e ed elasthan privi di lattice

**DIMENSIONI:** 17,5 \* 9,5 cm

**TIPO:** Tipo II R – monouso / non sterile – taglia unica adulto

**STANDARD FILTRAZIONE:** CE EN 14683: 2019+AC2019

**Condizioni di conservazione:** mantenere in condizione buie, secche e ben ventilate, lontano da fiamme libere e fonti di inquinamento.

### MENU

home

Shop

Carrello

Il mio account

### NEWSLETTER

Name Surname

e-mail

Send

### CONTACT US

Labventi S.r.l.

Corso Porta Nuova, 133

37122 Verona

C.F. e P.IVA 04709710232

e-mail: info@labventi.it

**PRODOTTO ITALIANO – MADE IN ITALY**





DS-Cloud



E-mail



OpenERP



Forum



DS-Note



Addressbook



Spare Parts  
Catalog

***VIDEO***



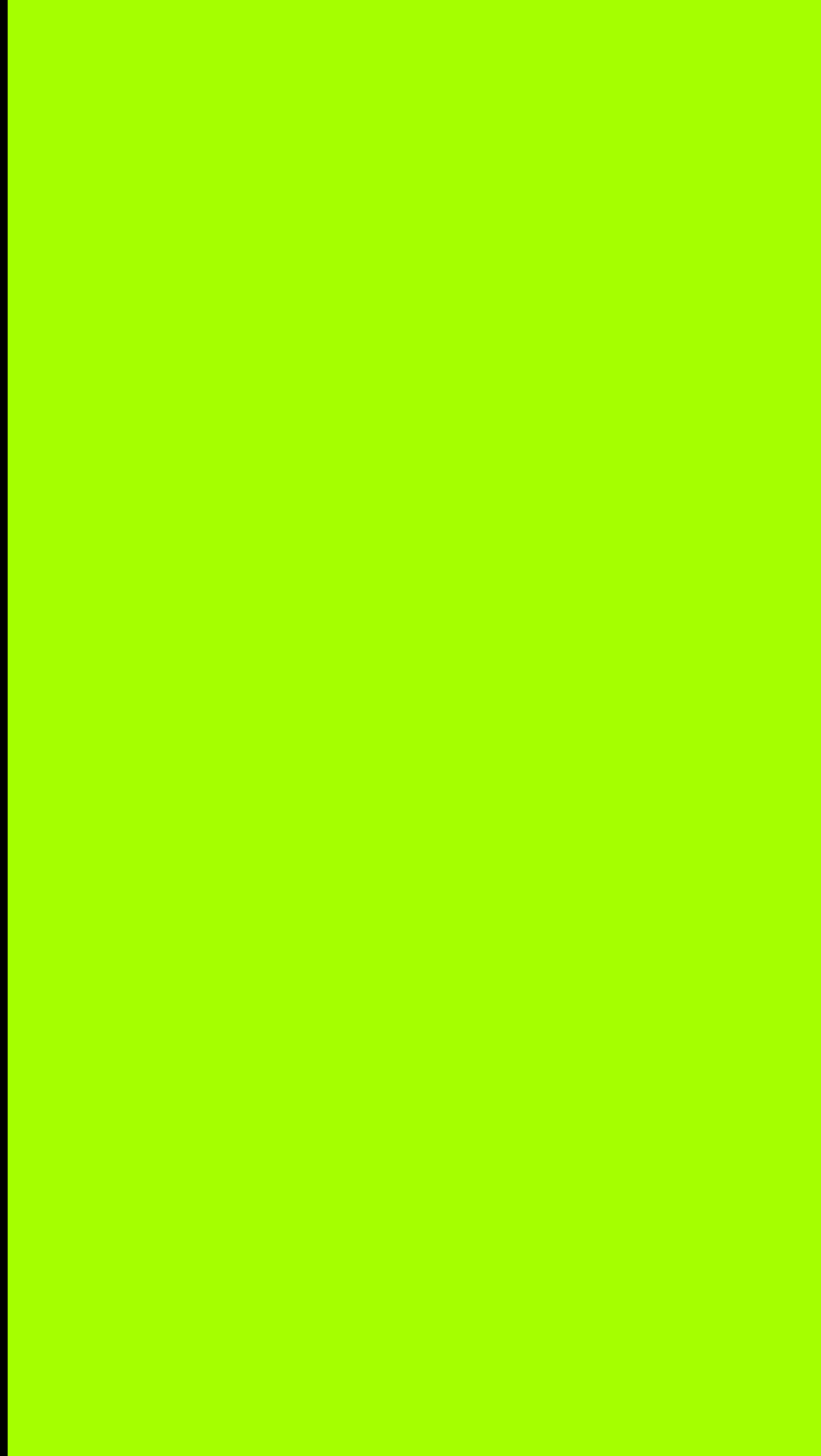



**2022  
trend**

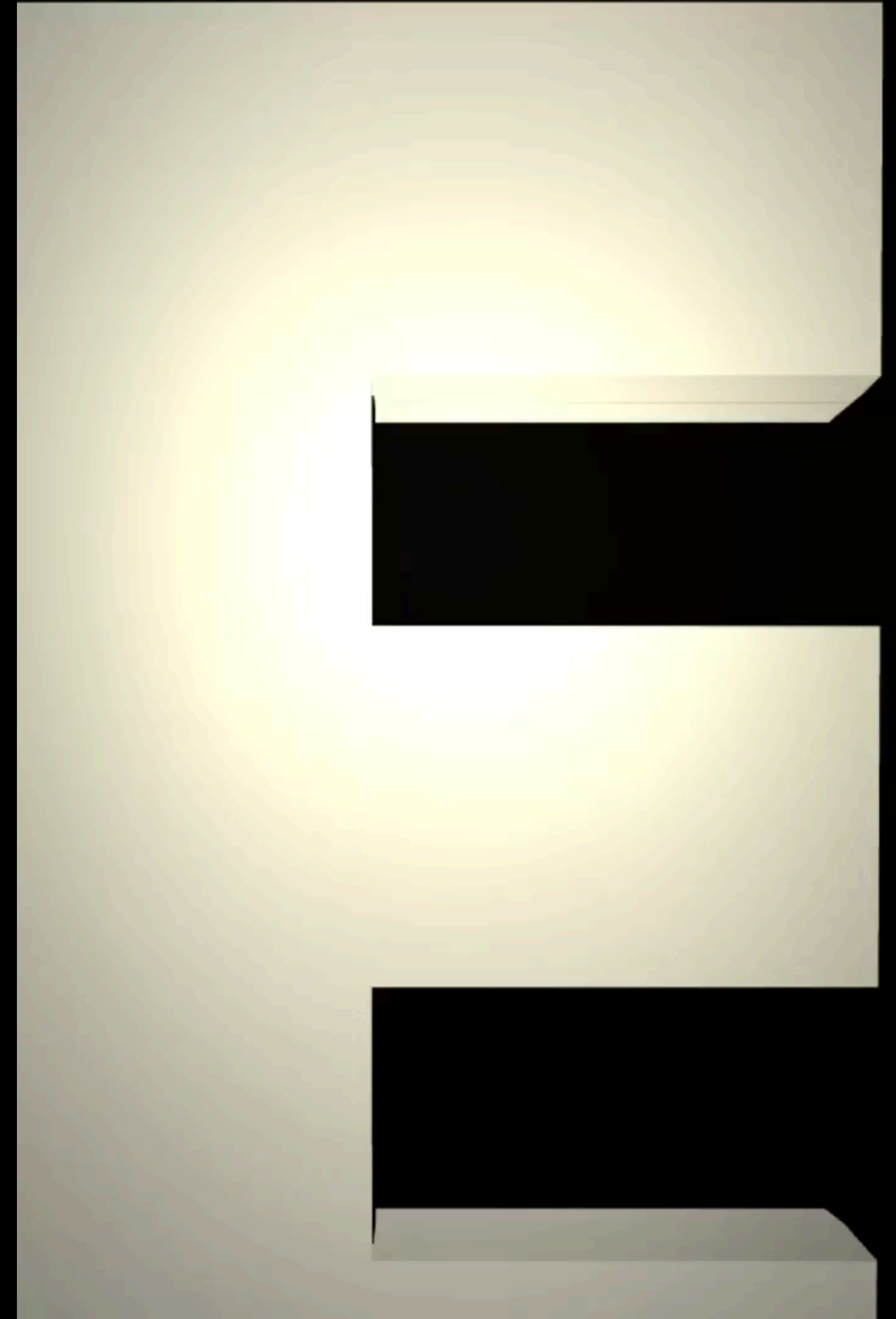

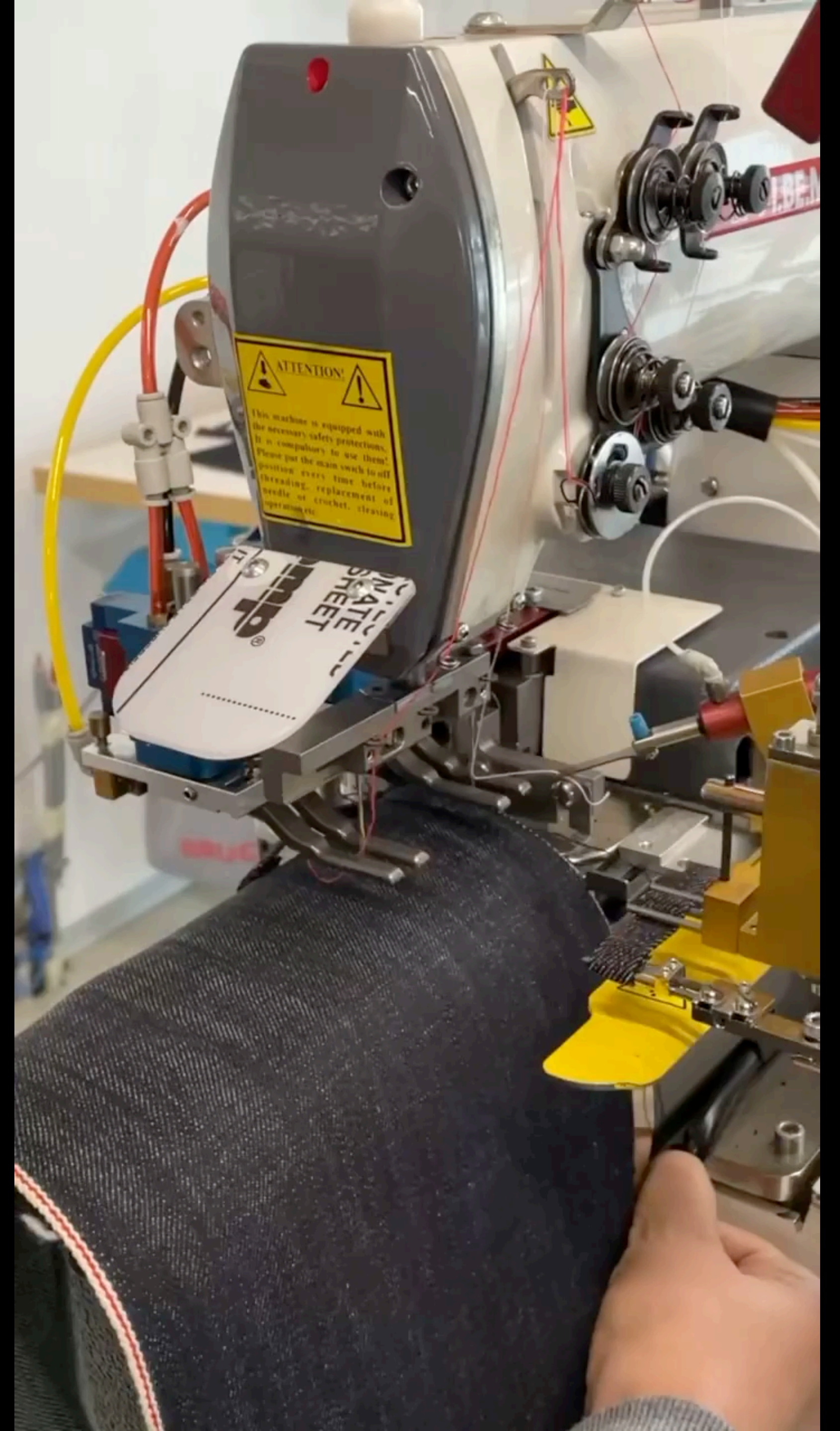



HALL 5.1

BOOTH B66

Messe Frankfurt

Kap Europa Convention Center Messe

Messe Frankfurt

GRIESHEIM

SACHSE

OBERRAD

Schwanheimer Dune

Eschborn

PRAUNHEIM

ECKENHEIM

SECKBACH

DORNBUSCH

GINNHEIM

HAUSEN

RODELHEIM

BORNHEIM

BOCKENHEIM

Giardino botanico  
Palmengarten

RIEDERWALD

Zoo Frankfurt

Parco Ostpark

OSTEND

NIED

Messe Frankfurt

641

Main



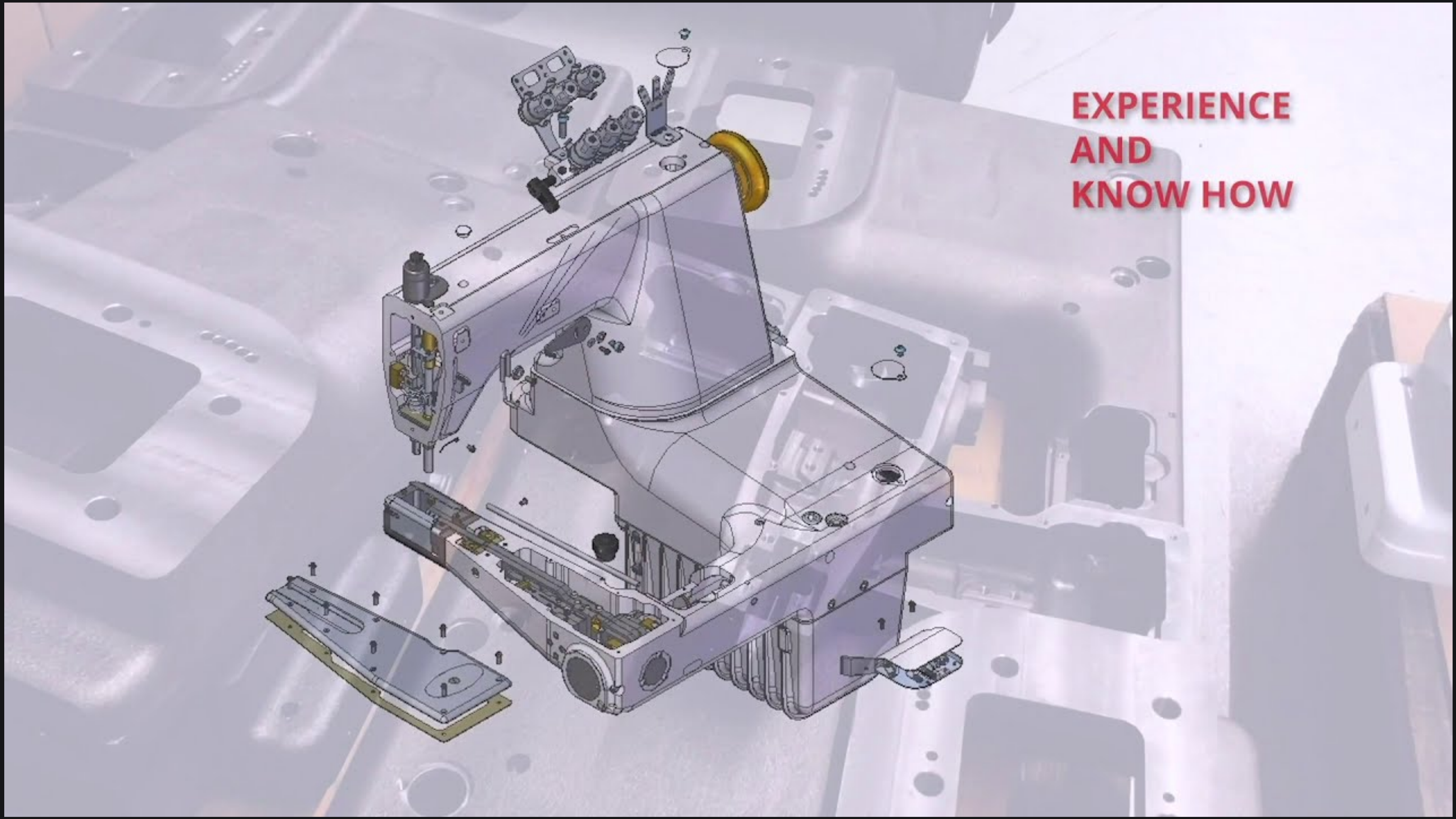

**EXPERIENCE  
AND  
KNOW HOW**

The background consists of several overlapping, semi-transparent shapes in shades of pink and orange. A large, bright pink circle is on the left side. A large, bright orange shape is on the right side. In the center, there are several overlapping shapes in various shades of pink and orange, creating a layered effect. The overall composition is abstract and modern.

***Illustrazioni***







# MAD ONE X BONOBOLABO

BIRRA ARTIGIANALE  
Prodotta da Mad One Srl - Via Beduschi 45 -  
26041 Casalmaggiore CR - ITALIA

INGREDIENTI  
Ingredienti: acqua, malto d'orzo, luppolo, lievito  
Conservare al fresco

4,5% vol.  
33 cl







Café

TIME

